

[54] HEAT PUMP

3,626,606 12/1971 Wallace 35/19

[76] Inventor: Henry W. Wallace, 60 Oxford Dr.,
Freeport, N.Y. 11520

Primary Examiner—William J. Wye

[22] Filed: Feb. 16, 1973

[21] Appl. No.: 333,206

[52] U.S. Cl. 62/56, 62/3, 62/467,
35/19

[51] Int. Cl. F25d

[58] Field of Search 62/3, 56, 467; 35/19 R

[57] ABSTRACT

Method and apparatus for utilizing for the purpose of heat flow by means of controlled temperature change a field energy, other than electric, magnetic or gravitational field energies, capable of reducing the specific heat properties of a broad class of substances.

[56] References Cited

UNITED STATES PATENTS

3,626,605 12/1971 Wallace 35/19

11 Claims, 14 Drawing Figures

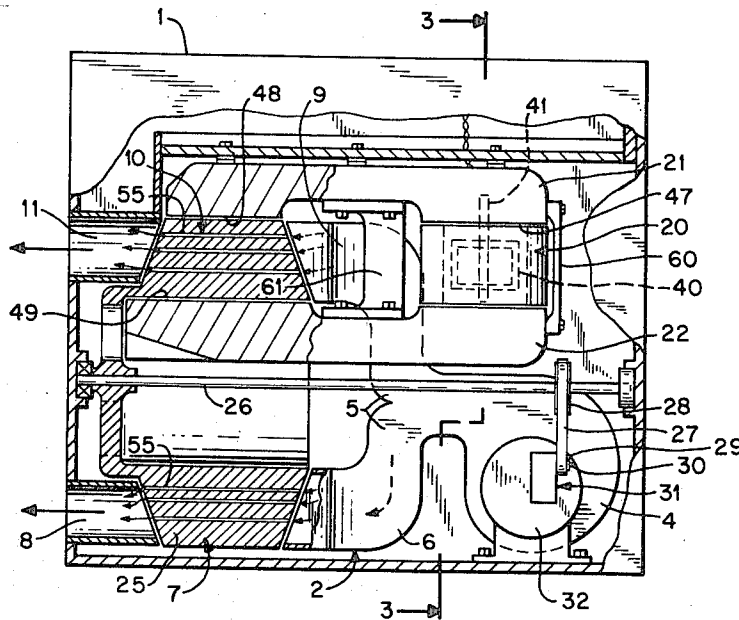

FIG. 1

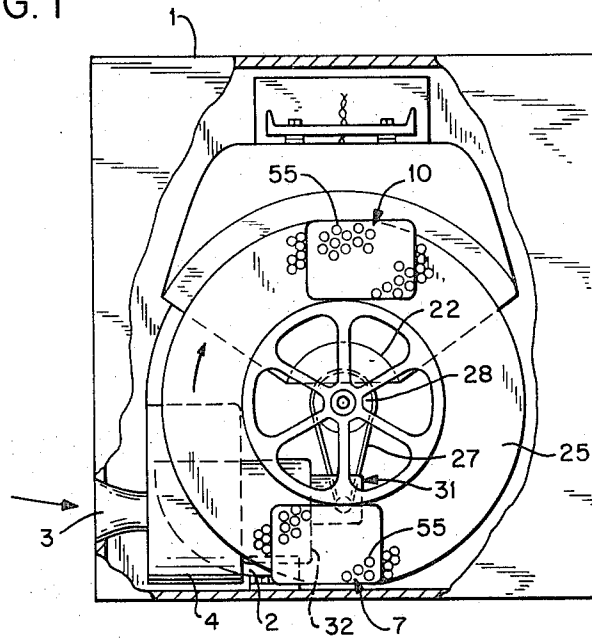

FIG. 2

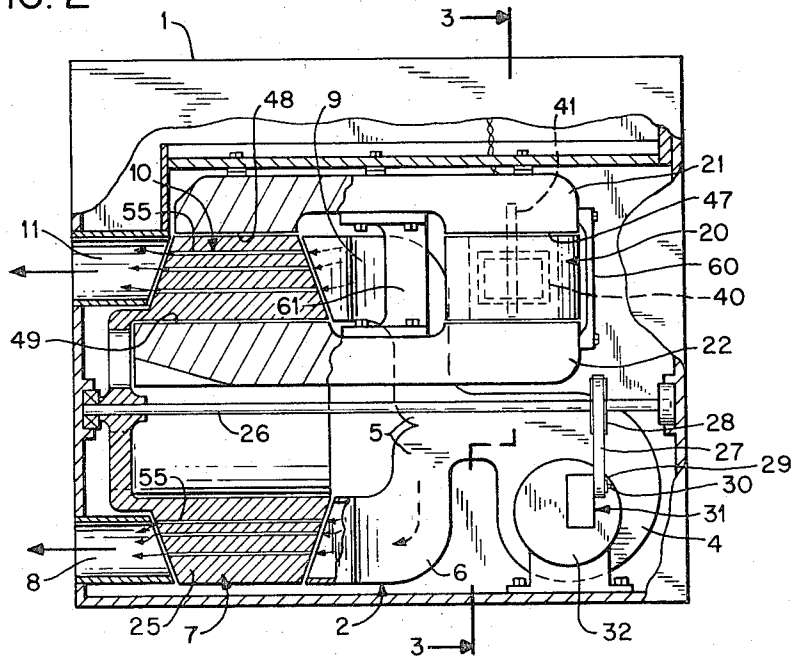

FIG. 3

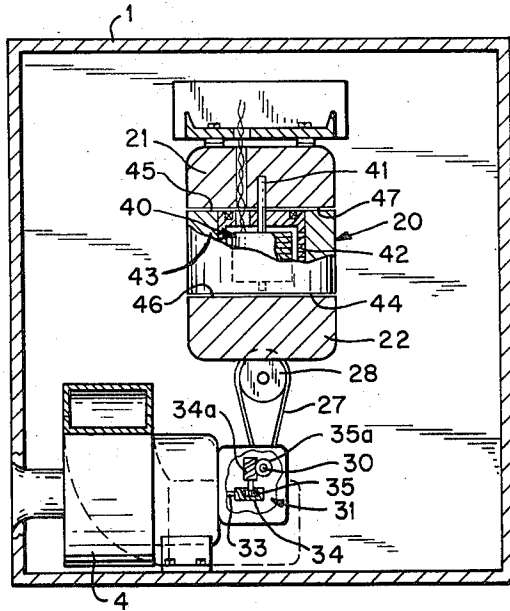

FIG. 5B

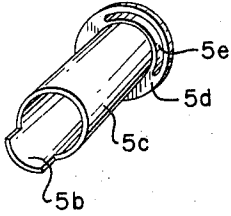

FIG. 5A

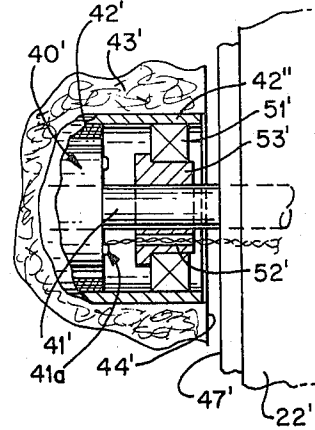

FIG. 5

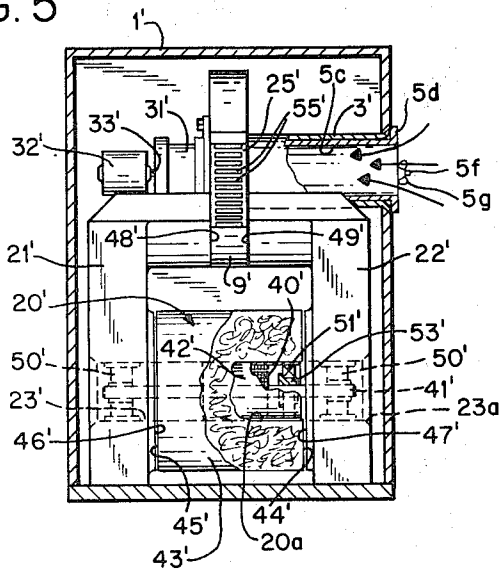

FIG. 4

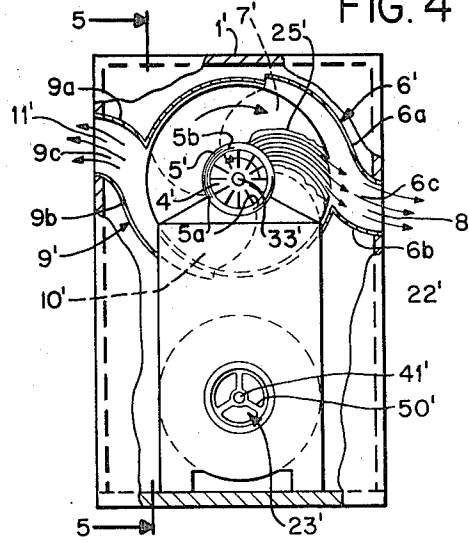

FIG. 6

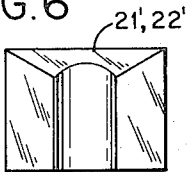

FIG. 7

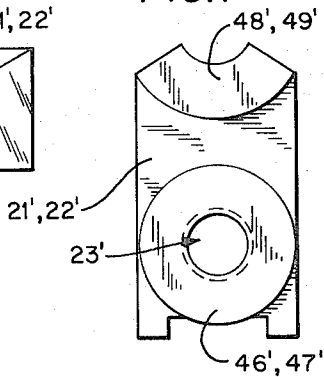

FIG. 8

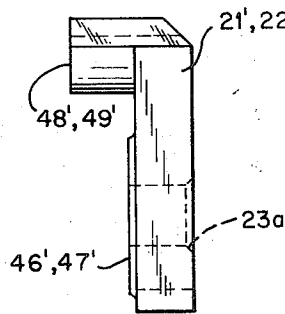

FIG. 9

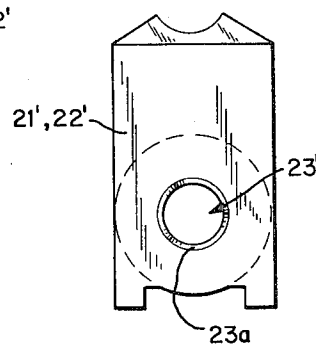

FIG. 10

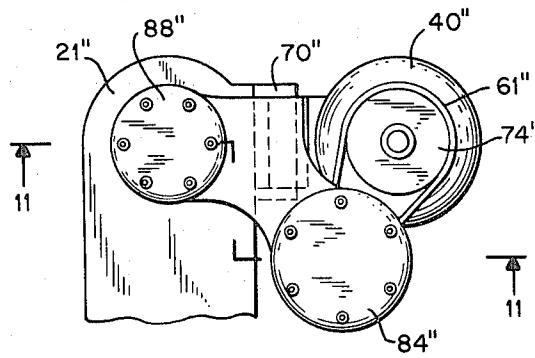

FIG. 11

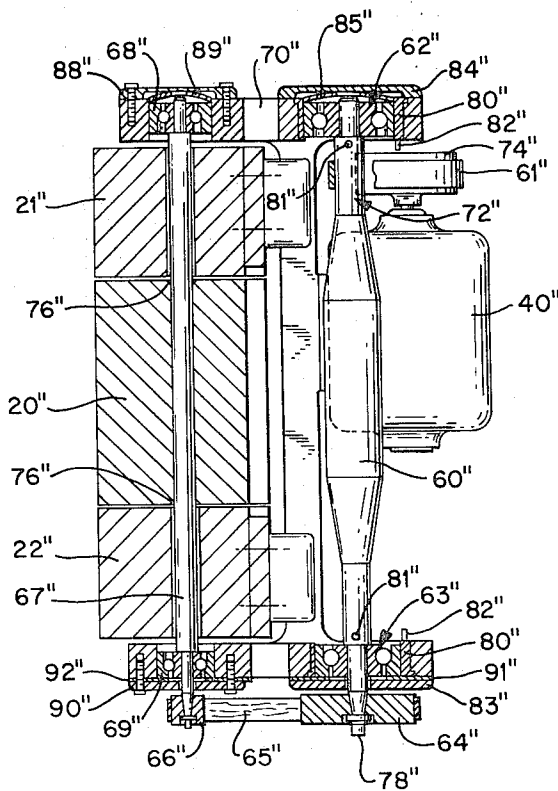
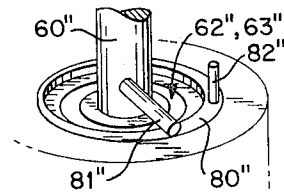

FIG. 12



HEAT PUMP

The present invention pertains to manipulation of atomic nuclear structure so as to modify the state of an energy transfer medium, and utilization of the modified medium. More particularly, the invention pertains to effecting reorientation of nucleons of a material whose spin number (I) is half-integral, and imposing the effect of such reorientation on a medium adapted to do productive work.

In the past century great strides have been made in harnessing the three degrees of translational movement of electrons in the electromagnetic regime. Very little, if anything, has been done to utilize the inertial regime comprising the relatively massive nucleons, and particularly the three degrees of rotational freedom thereof one of which is preempted by nuclear spin.

In my U.S. Pat. No. 3,626,606, I demonstrated how, by applying a rotational force to material whose nuclear spin number (I) is half-integral, a reorientation can be achieved in the nuclear structure. In my U.S. Pat. 3,626,605, I demonstrated how a time variant may be imposed on the output resulting from such reorientation.

It immediately becomes evident that there are potentially many, many uses of these reoriented nucleons. In all probability, techniques will be found which to some extent parallel those employed for utilization of the electron in the electromagnetic field, and it becomes clear that the thus reoriented nuclear structure may lend itself to such uses as modification of the gravitational field acting on a body so as to alter its gravitational attraction toward another body, separation of isotopes by distinguishing between nuclei according to their nucleon content, generating of gravity waves for communication and other energy transfer, stabilizing of plasma and maintenance of plasma density for controlled nuclear fusion, possible harnessing of cosmic gravitational energy in addition to utilization in many, many other fields.

For purposes of demonstration the utilization of the invention in heat pumps will be explained. For brevity, material whose spin number (I) is half-integral will be referred to hereafter as "spin nuclei material." As in U.S. Pat. Nos. 3,626,605 and 3,626,606, the generated field will be referred to as a "kinemassic" field.

The Spin Values (I) for the isotopic forms of the elements are well known and may be found in tabular form, for example, "The NMR Table, Fifth Edition," published by Varian Associates of Palo Alto, Cal. Typical among substances in elemental form having such half integral spin values are beryllium with a neutron spin of $I = 3/2$, aluminum with a proton spin of $I = 5/2$, chlorine of which both isotopes provide proton spins of $I = 3/2$, vanadium (useful for alloys) of which one isotope of 99.76 percent abundance provides a proton spin of $I = 7/2$, cobalt with a proton spin of $I = 7/2$, copper of which both isotopes provide spins of $I = 3/2$, and bromine of which both isotopes provide proton spins of $I = 3/2$. These chemical elements and others of half integral spin values may be alloyed together as well as to chemical elements possessing no-spin and integral spin nuclei provided quantity percentages of such additional elements are small.

In U.S. Pat. No. 3,626,606 it was explained that the kinemassic force resulting from this dynamic interaction of relatively moving bodies of spin nuclei material

can be utilized for temperature control purposes including the specific application of such kinemassic forces to the control of lattice vibrations within a crystalline structure thereby establishing an appreciable temperature reduction, these principles being useful, for example, in the design of a heat pump.

The half-integral spin nucleus of this spin nuclei material is characterized by possession of an odd nucleon, either neutron or proton, which is consequently unpaired. The remainder of the nucleons of such a half-integral spin nucleus are acted upon by both the short-range force and the weaker long-range force which together constitute the nuclear binding force. The unpaired nucleon is acted upon only by the weaker long-range force and it is the energy of the absent short-range force characterizing the half-integral spin nucleus which, in a polarized and therefore summed state, controls the crystal lattice vibrations by virtue of polarizing the half-integral spin nuclei contained therein due to their absent short-range force nuclear energy causing an available, responsive energy, this polarization resulting in a diminishing of the lattice vibrations within said crystalline structure.

The kinemassic field may be utilized in static form for reducing the specific heat of such spin nuclei material. Establishing of this static field energy within said atomic structure effectively reduces its specific heat capacity concomitantly causing a controlled temperature increase therein due to the presence of the substance's enthalpy content. This temperature increase in turn causes heat flow from this substance into ambient substance of lower temperature. Removal of this static field energy from within said atomic structure results in the rapid restoration of the natural specific heat which would normally be possessed by this substance commensurate with its now-reduced enthalpy content. Concomitantly there is caused to occur a decrease of temperature within this substance to a value below that of the temperature which is possessed prior to application of the static field energy. This below-ambient temperature is caused by the now-reduced enthalpy content which resulted from the heat flow away from the substance which had occurred when it contained the static field energy. As a consequence heat now flows back into this substance from the ambient substance of higher temperature.

It is provided for in this invention that the substance, with its controllable specific heat property, be capable of physical transport from one spatial location to another. However for the following explanation these locations will be limited to two in number. For both spatial locations, the ambient substance possesses an adequate thermal conductivity property. If now the static field energy is caused to be present within the transportable substance of controlled variable specific heat property, when at the first of these spatial locations but removed from this substance when it has been transported to the second of these locations, it is evident that heat flow from the transportable substance into the ambient substance will always occur at the first location identified by the presence of the static field energy and that heat flow from the ambient substance into the transportable substance will always occur at the second location identified by the absence of the static field energy. It is then apparent that the transported substance of spin nuclei material alternately and cyclically experiences temperature changes such that, at the designated

first location, its temperature exists at a value higher than that of the temperature of the ambient substance and, also, at the designated second location, that its temperature exists at a lower value than that of the temperature of the ambient substance. This one-way heat flow from the transported substance into the ambient substance of the designated first location in combination with the one-way heat flow from the ambient substance of the designated second location into the transported substance, this dual heat flow phenomena, then constitutes a heat pump.

Although several techniques are known for altering specific heat, such as changing the density of a gas, the technique utilized in this invention concerns the limiting of the degrees of freedom of particle vibration of a substance by means of a static field energy. More specifically, consider the thermal vibration of a crystal lattice structure. The assembly of atoms bound together by local interatomic forces, composing a crystal lattice, is capable of vibrating in a large number of independent normal modes about a static equilibrium configuration. In these vibrations a large portion of the enthalpy is stored; these vibrations are the major contribution to the structure's specific heat.

One object of the invention is to utilize the so-called kinemassic force to alter the energy state of a relatively movable medium.

A further object is to condition spin nuclei material so that it will alternately cause heat to flow out of it into it by means of temperature change.

A further object is to utilize the kinemassic force field concept in a heat pump.

According to the present invention there is provided a method of modifying the energy state of a relatively movable transfer medium, which comprises applying to a material whose nuclear spin number (I) is half-integral a force which reorients nucleons thereof, exerting on a transfer device a force resulting from said reorientation, and exposing said relatively movable transfer medium to said device to effect said modification of the energy state of said medium.

The invention also provides a heat pump comprising a rapidly rotatable generator formed of spin nuclei material, a relatively stationary body of spin nuclei material closely juxtaposed to said generator and forming therewith a closed field circuit, and heat transfer means formed of spin nuclei material and adapted to move through the vicinity of said relatively stationary body whereby the specific heat of said heat transfer means is altered to accomplish useful work.

In order that the disclosure will be more fully understood and readily carried into effect, the following detailed description is given with reference to the accompanying drawings in which:

FIG. 1 is an end view, with housing partly removed, of a heat pump according to the present invention.

FIG. 2 is a side view, with housing partly removed, of the heat pump shown in FIG. 1.

FIG. 3 is a sectional view taken along the line 3—3 of FIG. 2.

FIG. 4 is an end view, with housing partly removed, of another embodiment of the solid state heat pump.

FIG. 5 is a sectional side view taken along line 5—5 of FIG. 4.

FIG. 5A is a detailed view of a portion of FIG. 5.

FIG. 5B is a parallel perspective view of a component part of FIG. 5.

FIGS. 6, 7, 8 and 9 show respectively top, front, side and rear views of symmetrical field circuit segments employed in the embodiment of FIGS. 4 and 5.

FIG. 10 is an end view of a further modification of the invention.

FIG. 11 is a sectional view taken along the line 11—11 of FIG. 10, and

FIG. 12 is a detailed view of one aspect of the eccentric adjustment.

FIGS. 1 to 3 show a solid state heat pump. As disclosed in FIGS. 1 and 2, housing 1 encloses a duct system 2. Air or other fluid is conducted through inlet 3 and into blower 4. Air under pressure emerging from blower 4 is conducted to manifold 5 where it is divided into two air streams one of which flows through lower duct 6 to reduced-temperature heat flow zone 7 and then to exhaust outlet 8. The other stream of air from manifold 5 flows upwardly through upper duct 9 to increased-temperature heat flow zone 10 and then to exhaust outlet 11.

The kinemassic force, which is utilized in accordance with the invention to effect the desired heat flow is generated in a kinemassic generator rotor 20. Portions of an upper field circuit segment 21 and a lower field circuit segment 22 are juxtaposed to rotor 20 to form therewith a part of a kinemassic field circuit. At the increased-temperature heat flow zone 10 a heat flow is effected with air or other fluid as hereinafter described.

To achieve this heat flow, an enthalpy transfer ring 25 is rotatable on a shaft 26 driven by a belt 27 through a pulley 28 mounted on said shaft 26. Said belt 27, in turn, is driven by pulley 29 mounted on a shaft 30 forming a part of a gear reduction assembly 31. Blower 4 is driven by blower motor 32 which also is connected to a rotor shaft 33 (FIG. 3) and worm gear 34 through a worm wheel 35 which is integral with a second worm gear 34a which, in turn, drives a worm wheel 35a connected to shaft 30.

As seen in FIG. 3 the kinemassic generator rotor 20 includes a generator drive motor 40 which, in the present embodiment, is shown as an inside-out electric motor having shaft 41 mounted integrally on upper field circuit segment 21. The motor may, for example, be a hysteresis type motor and driven by a solid stage frequency-controlled source.

The outer housing 42 of drive motor 40 is adapted to rotate and has integrally mounted thereon a cylindrical generator rotor member 43 formed of spin nuclei-containing material. Drive motor 40 is adapted to rotate cylindrical generator rotor member 43 at extremely high rates of rotation. The kinemotive force generated is a direct function of rate of rotation, so that it is desirable to achieve the highest rate of rotation compatible with the permissible stresses in the system. These stresses vary with the physical size an proportions of said cylindrical generator rotor member 43 and the material of which it is composed. Such rates of rotation can range from approximately 30,000 RPM to values of 100,000 RPM or greater, the lower limit preferably being in the neighborhood of 50,000 RPM.

Cylindrical generator rotor member 43 is formed with flat pole face surfaces identified as generator lower pole-face 44 and generator upper pole-face 45 at its lower and upper ends respectively which are juxtaposed to flat pole face surfaces identified as lower field pole-face 46 and upper field pole-face 47 forming a

part respectively of lower field circuit segment 22 and upper field circuit segment 21. It is essential to maintain air gaps of minimum width between pole face surfaces 44, 46 and between pole face surfaces 45, 47 in order to provide maximum kinemassic field circuit permeability as well as to optimize the secondary interaction of kinemassic field generating.

The upper and lower field circuit segments 21 and 22 are formed of spin nuclei-containing material and each terminates adjacent enthalpy transfer ring 25 as upper enthalpy transfer pole-face 48 and lower enthalpy transfer pole-face 49, respectively. The pole faces 48 and 49 are cylindrical surface segments and are equal in surface area. As seen in FIGS. 1 and 2, these respective pole faces 48 and 49 so encompass a portion of enthalpy transfer ring 25 that they provide for minimum kinemassic field reluctance of the flux lines passing through that portion of enthalpy transfer ring 25. In order to minimize reluctance, the respective air gaps formed by pole faces 48 and 49 and the juxtaposed portion of enthalpy transfer ring 25 should be of minimum air gap width.

Enthalpy transfer ring 25 is provided with a multiplicity of enthalpy transfer surfaces which may be in the form of tubular channels 55 which, in part, function to increase the enthalpy transfer surface area resulting in greater heat flow between the enthalpy transfer ring 25 and an enthalpy transfer fluid which is caused by blower 4 to flow through duct 9, through these tubular channels 55 and then to exhaust outlet 11. The tubular channels 55, only a few typical ones of which are shown, have a second function of reducing the cross-sectional area of a kinemassic field circuit in the increased-temperature heat flow zone 10 in order to increase the flux density within the permeable portion of ring 25 within zone 10 while imparting a minimum increased reluctance to the over-all field circuit. This increased flux density within the permeable portion of ring 25 within zone 10 results in greater reduction of the specific heat of ring 25 within zone 10. The tubular channels 55 may be variously configured and distributed to achieve the foregoing results.

End plate 60 may be accurately pinned then bolted to circuit segments 21 and 22 to maintain the air gaps in position and to support segment 22. Also, connecting block 61 is provided at an intermediate position between segments 21 and 22 for the same purpose.

In operation, after the kinemassic generator rotor 20 has been caused to spin at a high rate of rotation, air fed through inlet 3 is propelled by blower 4 to manifold 5 where it is subdivided into a lower stream flowing through duct 6 and an upper stream flowing through duct 9.

The enthalpy transfer ring 25, which rotates at a suitably slow speed, for example, one revolution per minute, will undergo a reduction in specific heat in any given portion then under the influence of the kinemassic force extending between pole faces 48 and 49. The air passing through upper duct 9 will be forced through those tubular channels 55 which are at the instant in the increased-temperature heat flow zone 10 adjacent pole pieces 48 and 49 with the result that the air will experience a temperature rise caused by that heat flow into it resulting from the temperature rise occurring in said given portion of enthalpy transfer ring 25 due to the reduction in its specific heat arising from the polarization of its spin nuclei under the influence of

the kinemassic force, whereby the air which emerges from exhaust outlet 11 will possess a temperature higher than its temperature possessed when it previously flowed through duct 9.

As enthalpy transfer ring 25 continues to rotate, so that said portion thereof departs from the spin nuclei polarizing effect of the kinemassic field flux lines of zone 10, the specific heat will increase again to its normal value thereby causing the temperature of said given portion to drop below that value existent prior to entering zone 10 because of the reduced enthalpy now contained therein. The lower stream of air is forced from duct 6 through those tubular channels 55 in the reduced-temperature heat flow zone 7 with the result that said given portion of enthalpy transfer ring 25, due to its changed state of increased specific heat, will absorb heat from the ambient flowing air, as said given portion of ring 25 reaches zone 7, the result being that the air emerges from outlet 8 with a temperature lower than that temperature possessed when it was flowing through duct 6. It will be noted, as can be seen from FIG. 2, that the increased-temperature heat flow zone 10 is offset, with respect to the vertical, from reduced-temperature heat flow zone 7, this offsetting being desirable for optimum coordination of the specific heat reduction and recovery times respectively of the chosen material forming ring 25 in its passage into and from the zone 10. The positions and configuration of zones 7 and 10 may be varied depending on the specific heat properties of the material forming ring 25.

Turning now to the embodiment of FIGS. 4 to 9, the same reference numerals have been used, so far as feasible, as in FIGS. 1 to 3 but with primes. The housing 1' encloses a duct system comprising an inlet duct 3', best shown in FIG. 5, which leads air to a rotary blower 4' mounted on rotor shaft 33' driven by blower motor 32' through, but by-passing, a drive unit 31' which may be, if desired and as shown, in the form of a harmonic drive unit manufactured by USM Corporation of Shelton, Connecticut.

An enthalpy transfer ring 25' is also mounted for rotation about rotor shaft 33', and is driven by blower motor 32' through drive unit 31' in counterrotation to rotary blower 4'. While the rate of rotation of rotary blower 4' is preferably between 1,745 and 3,500 RPM, the rate of counterrotation of enthalpy transfer ring 25' is relatively slow, for example, one to several revolutions per minute. A reduced-temperature duct 6' for leading cooled air from the system to an exhaust 8' is formed by upper baffle 6a and lower baffle 6b and side baffle 6c as shown in FIG. 4 and another similar side baffle (not shown), the width of duct 6' being sufficient to snugly overlap enthalpy transfer ring 25'. Similarly, an increased-temperature duct 9' for leading heated air from the system to an exhaust 11' is formed by upper baffle 9a, lower baffle 9b, side baffle 9c and another side baffle (not shown), the width of duct 9' also being sufficient to snugly overlap enthalpy transfer ring 25'.

Kinemassic generator rotor 20' is provided for generating the desired kinemassic force. As seen in FIGS. 5 and 5A the rotor 20' includes a generator drive motor 40' which may be of the so-called "inside-out" type having a stationary shaft 41' on which is mounted a winding 41a. The drive motor 40' may be powered by a generator or solid state frequency converter (not shown) preferably with an output frequency of approx-

imately 1,234 cps. In this embodiment an oil mist supply (also not shown) should be provided for bearing lubrication. The oil mist can, for example, be delivered by a small size air compressor unit. Concentrically mounted on shaft 41' is a rotatable outer iron rotor and conductor cage 42' fitted into housing 42'' of generator drive motor 40'. Integrally mounted on said rotatable iron rotor and outer conductor cage 42' is a cylindrical generator rotor member 43' formed of spin-nuclei-containing material. Cylindrical generator rotor member 43' is formed with flat pole faces 44' and 45'. Juxtaposed thereto are flat field pole faces 46' and 47' of field circuit segments 21' and 22' formed of spin-nuclei-containing material and adapted to provide a path for kinemassic flux between generator rotor member 43' and transfer ring 25'. It is essential to maintain air gaps of minimum width between pole-face surfaces 44', 47' and between pole-face surfaces 45', 46' in order to provide maximum kinemassic field circuit permeability, the width of the air gaps in the drawings being exaggerated for clarity.

The rotor 20' is provided with an axial cylindrical recess 20a adapted to mate with axial cylindrical recesses 23' provided in field circuit segments 21' and 22' the outer edges 23a of recesses 23' being beveled as shown in FIG. 5. Fitted into each of the recesses 23' are respective shaft mounts 50' which non-rotatably secure the shaft 41' to segments 21' and 22', the motor 40' fitting firmly within axial cylindrical recess 20a. The motor 40' may, for example, be a hysteresis type motor driven by a solid state frequency controlled source. The outer iron rotor and conductor cage 42' of motor 40' rotates about the stationary motor shaft 41' through its mounting on generator drive motor bearings 51' of which there are a pair but only one of which is shown. A concentric bearing block 53' associated with each of the bearings 51' contains in the illustrated block the power leads for the generator drive motor 40' through power lead channel 52'.

The identical first and second field circuit segments 21' and 22' each terminate adjacent enthalpy transfer ring 25' as first enthalpy transfer pole-face 48' and second enthalpy transfer pole-face 49', respectively. The first enthalpy transfer pole-face 48' and the second enthalpy transfer pole-face 49', in this embodiment, are identical in configuration and having flat surfaces and are of hollow circular segment form as best shown in FIGS. 6 to 9. As seen in FIGS. 4 and 5, these respective pole-faces 48' and 49' so encompass a portion of enthalpy transfer ring 25' about portions of its flange surfaces that they provide for minimum kinemassic reluctance of the flux lines passing through that portion of enthalpy transfer ring 25'. The respective air gaps formed by pole-faces 48' and 49' and the adjacent flanges of enthalpy transfer ring 25' should be of minimum width. Enthalpy transfer ring 25' is provided with a multiplicity of enthalpy transfer surfaces which may be in the form of involute channels 55' the involute surfaces of which may be described by the x, y coordinate equations:

$$x - a \cos \phi + a \phi \sin \phi \text{ and } y = a \sin \phi - a \phi \cos \phi$$

where "a" is the inner radius of the enthalpy transfer ring 25' and ϕ is the polar angle described between the starting point and tangent point of a string which is kept taut while being unwound from a cylindrical surface of radius "a," the curve formed by the string end describ-

ing the involute surface of the channel. Such an involute channel in conjunction with the contrarotating relation between blower 4' and enthalpy transfer ring 25' serve to enhance the enthalpy transfer effect between involute surface and the fluid due to the surface impingement arising from the angular paths required of the fluid particles. More important, the involute channels 55' permit a uniform cross-section of field permeable material distribution from inner radius to outer radius of the enthalpy transfer ring 25' while, also, causing the kinemassic field flux density increase described for the first embodiment.

As shown in FIG. 4, the periphery of blower 4' is partially surrounded by fixed shrouds 5a and an adjustable shroud 5b adapted to control the amount of air flowing into ducts 6' and 9'. The adjustable shroud 5b is attached by bolt and slot connections to the housing of blower 4'. The adjustable shroud 5b is integral with inlet sleeve 5c as shown in FIG. 5B in parallel perspective. Inlet sleeve 5c is designed to concentrically nest, in a rotatable sliding relation, within inlet duct 3' as shown in FIG. 5. Flange 5d of inlet sleeve 5c possesses an arc slot 5e of a sufficient number of angular degrees that, in conjunction with a bolt stud 5f secured to housing 1' and extending through are slot 5e in combination with wing nut 5g, adjustable shroud 5b can be fixed in any required angular orientation so as to apportion the air flow in cooperation with shrouds 5a into ducts 6' and 9'.

In operation air under pressure emerging from blower 4' is divided into two air streams by means of the shrouds 5a and 5b. One air stream flows directly into a reduced-temperature enthalpy transfer zone 7' and then through reduced-temperature duct 6' to exhaust 8'. The second air stream flows directly into increased-temperature enthalpy transfer zone 10' and then through increased-temperature duct 9' to exhaust 11'. The fixed shrouds 5a are carefully positioned for directing the air into the two enthalpy transfer zones 7' and 10'. The number of involute channels 55' which are effective at any one time to pass air through enthalpy transfer zones 7' and 10' can be adjusted by varying the setting of movable shroud 5b. By adjusting said movable shroud 5b so as to reduce the air flow rate through the reduced-temperature enthalpy transfer zone 7', while simultaneously increasing the air flow rate through the increased-temperature enthalpy transfer zone 10', a lesser amount of enthalpy will be transferred into the enthalpy transfer ring 25' than will be transferred out of said ring within the increased-temperature enthalpy transfer zone 10', thus resulting in a gradually increasing enthalpy deficit in enthalpy transfer ring 25'. This then will cause the mean temperature of the enthalpy transfer ring 25' to reduce until there is no longer an imbalance between the rate of enthalpy introduced and the rate of enthalpy removed from the enthalpy transfer ring 25'. Thus, there is provided a self-stabilizing system since the temperature difference between the ambient temperature air, arriving through inlet duct 3' into the involute channels 55' within the increased-temperature enthalpy transfer zone 10', and the surface temperature of the involute channels 55' will diminish as the average temperature of the enthalpy transfer ring 25' reduces.

The extremes of temperature difference of enthalpy transfer ring 25', occurring between the maximum existent in those involute channels 55' located in the en-

thalpy transfer zone 10' and the minimum existent in those involute channels 55' located in the enthalpy transfer zone 7', not only are dependent upon their temperature values above 0°K as reflected by the average temperature of enthalpy transfer ring 25', but also by the particular half-integral spin nuclei utilized in the enthalpy transfer ring 25'. These temperature differences are therefore limited and consequently determine the temperature at which self-stabilization will occur as exemplified by that state where the temperature of the air or other fluid entering inlet duct 3' is of the same value as that temperature of the involute channels 55' located in the enthalpy zone 10'. That temperature at which self-stabilization occurs can be significantly lowered by returning to inlet duct 3', by means of commonplace ducting and therefore not shown, a portion of the lower temperature air leaving reduced-temperature duct 6' to exhaust 8'. Thus the average temperature of enthalpy transfer ring 25' can be lowered to a values considerably greater than that temperature difference existent in enthalpy transfer ring 25' between its maximum and minimum values at any moment of time.

It is therefore significant to note that a reduction of the enthalpy transfer ring 25 or 25' mean temperature of from 70° to 35°F represents a reduction of only 6.6 percent with respect to 0°K and that this technique of heat pumping via the cyclic changing of a material's specific heat by way of the kinemassic field force is not restricted to a narrow temperature range as is the case in the conventional heat pump with its narrow limits of temperature-pressure parameters required for boiling and condensing states. For example, the temperature difference between the inflowing air or other fluid entering inlet duct 3' and the outgoing air or fluid leaving exhaust 8' can thus be increased by adjusting the blower motor movable shroud 5b, or by other equivalent controls, so as to reduce the air or fluid rate of flow through those involute channels 55' located within the reduced-temperature enthalpy transfer zone 7' and simultaneously increasing the air or fluid rate through those involute channels located within the increased-temperature enthalpy transfer zone 10' while causing the temperature of the outgoing air or other fluid of exhaust 8' to be progressively lowered by means of the reintroduction of a portion of this reduced-temperature air or other fluid of exhaust 8' back into the inlet duct 3'.

Conversely, if it is desired to increase the air or fluid temperature difference between the inflowing air or fluid entering inlet duct 3' and the outgoing air or fluid leaving increased-temperature duct 9' while progressively increasing the temperature of the outgoing air or other fluid of exhaust 11', the blower motor movable shroud 5b is adjusted so as to reduce the air or fluid flow rate through the increased-temperature enthalpy transfer zone 10' and simultaneously increasing the air or fluid flow rate through the decreased-temperature enthalpy transfer zone 7' while reintroducing a portion of this increased-temperature air or other fluid of exhaust 11' back into inlet duct 3', this resulting in a mean temperature increase of the enthalpy transfer ring 25'.

Blower motor movable shroud 5b may also be adjusted by a temperature-responsive servo drive system, of conventional design and therefore not shown, which is temperature sensitive to the air or other fluid leaving

exhaust 8' or to that of an enclosure, whose temperature is being controlled by this air or other fluid, thus providing an especially effective means of removing enthalpy from a solid or fluid through a broad temperature range. Such a conventional servo system can also be applied to the air or other fluid leaving exhaust 11' or elsewhere that temperature feedback is possible in order more effectively to establish and control elevated temperatures. Where system performance is closely repeatable, a simple time-controlled mechanism may be substituted for either servo system application in driving the blower motor movable shroud 5b.

Referring to the embodiment shown in FIGS. 10, 11 and 12 a modified kinemassic force generator system is shown to demonstrate advantages to be gained by the presence of additional, usable spin nuclei material at lesser inner diameters occupied by the generator drive motors 40 and 40' in the other embodiments and by increasing in the axial direction the length of the generator rotor 20'', such increase being possible without adding to the centrifugal force on the material forming the generator rotor 20'' thereby causing a kinemotive force of greater magnitude to occur for a given set of air gaps formed between a generator rotor 20'' and field circuit segments 21'' and 22''.

Field circuit segments 21'' and 22'' are shown juxtaposed to end surfaces of generator rotor 20'' in a manner similar to the juxtaposition of segments 21' and 22' to generator rotor 20' in FIG. 5. Field circuit segment 21'' is shown in fragmentary form in FIG. 10 to indicate that various uses may be made of the output of generator rotor 20''. For example, by suitable configuration of segments 21'' and 22'' the kinemassic force may be led to a transfer ring such as transfer ring 25' of FIG. 4.

In the present embodiment, generator drive motor 40'', drives a spindle 60'' through the intermediary of a belt 61'', said spindle 60'' being rotatable in suitable bearing assemblies 62'' and 63''. Mounted at the end of spindle 60'' opposite belt 61'' is a drive pulley 64'' which is connected by a belt 65'' to a driven pulley 66'' secured to a drive shaft 67'' adapted to rotate generator rotor 20''. Drive shaft 67'' is rotatably mounted in suitable bearing assemblies 68'' and 69'' supported in a generator drive chassis 70'' together with bearing assemblies 62'' and 63''.

Typical specifications for generator rotor 20' may be that it be formed of aluminum alloy with 15.24 cm outside diameter and 20.32 cm. axial length. Shaft 67'' may be of steel with 19 mm. outside diameter. Shaft 67'' may be push fit and secured to generator rotor 20'' with an epoxy adhesive. Generator rotor 20'' may be designed to rotate at 48,300 RPM. To achieve this angular velocity, drive motor 40'' may be a one-sixth HP. capacitor start, induction run type 115 VAC-single phase 3,450 RPM rated motor.

The spindle 60'' may be provided with a pulley section 72'' adapted to be rotationally engaged by belt 61''. Pulley 74'' driven by motor 40'' and adapted to drive belt 61'' may be a low-speed 8.89 cm. diameter minimal crown type. Belt 61'' may be of seamless polyflex material. The outside diameter of pulley section 72'' may be 2.54 cm. thus providing a 3.5 to 1 ratio between pulley section 72'' and pulley 74''. Thus, spindle 60'' will be driven at 12,075 RPM.

Pulley 64'' may be of intermediate-speed 10.2 cm. diameter minimal crown type. Pulley 66'' may be of

high-speed 2.54 cm. diameter type, thus providing a 4 to 1 ratio between pulley 66'' and pulley 64''.

The field circuit segments 21'' and 22'' may be formed of cast aluminum. The air gaps between segments 21'' and 22'' and generator 20'' should advantageously be held to 0.005 mm. but are exaggerated for clarity. Chamfers 76'' on each end of generator 20'' should be 45° × 1.6 mm.

The driving pulley 64'' may be secured to spindle 60'' by cap lock nut 78''. Bearing assemblies 62'' and 63'' may each be provided with eccentric collars 80'' adapted to be adjusted by pin sets 81'' and 82'' for belt tension control as shown in FIG. 12. Pin sets 81'' and 82'', only one set being depicted in FIG. 12, assure equal degrees of eccentricity adjustment of eccentric collars 80'' thus maintaining a parallel orientation between the respective axes of spindle 60'' and drive shaft 67'' while adjusting their separation distance for the purpose of tension control of belt 65''. After such adjustment, pin sets 81'' and 82'' are removed and the proper tensioning of belt 61'' is caused by means of laterally moving the generator drive motor 40'' with respect to generator drive chassis 70'' by conventional means. Bearings 62'' and 63'' may for example be Series 2MM9104 W1-CR, manufactured by the Fafnir Bearing Company of New Britain, Connecticut. Bearing assembly 63'' is provided with bearing thrust cap 83''. Bearing assembly 62'' is provided with spring thrust cap 84'' and thrust spring 85'' which may be a disc-type spring (Series AK) manufactured by the National Disc Spring Division, a subsidiary of the Rolex Company of Newark, New Jersey.

Bearing assemblies 68'' and 69'' may each be a Series 2MM9100 W1-CR, manufactured by the Fafnir Bearing Company. Bearing assembly 68'' may be provided with spring positioning cap 88'' and thrust spring 89'' which may be a disc-type spring (Series AK) manufactured by National Disc Spring. Bearing assembly 69'' may be provided with bearing positioning cap 90'' and bearing assemblies 63'' and 69'' may each be longitudinally adjusted with shims 91'' and 92'' which may be of ground plate and/or shim stock.

It has thus been demonstrated how the energy characterizing the half-integral spin nucleus can be utilized in a heat pump by altering the degrees of freedom of the crystal lattice structure. It is interesting to note that the assembly of atoms bound together by local interatomic forces to make up this crystal lattice structure is capable of vibration in a large number of independent normal modes about the static equilibrium configuration. In these vibrations is stored a large portion of the enthalpy of the solid, and hence the vibrations are believed to make the major contribution to the specific heat. The vibrational energy is quantized so there is recognized to be some zero-point motion even at 0°K.

While the inventive concept has been specifically demonstrated as applied to utilization in heat pumps, it will now be evident that the energy which characterizes the half-integral spin nucleus in fact provides a generally usable new tool for producing interactions among atomic structures and is in no way limited or restricted

to such use in heat pumps or similar devices.

I claim:

1. A method of modifying the energy state of a relatively movable transfer medium, which comprises applying to a material whose nuclear spin number (I) is half-integral a force which reorients nucleons thereof, exerting on a transfer device a force resulting from said reorientation, and exposing said relatively movable transfer medium to said device to effect said modification of the energy state of said medium.

2. A method of transferring heat which comprises effecting rapid rotary motion of a body of spin nuclei material to generate a kinemassic force field, causing said force field to interact with a relatively stationary body of spin nuclei material forming with said rotating body a closed circuit for said field, and moving through the vicinity of said relatively stationary body a heat transfer means comprising spin nuclei material, whereby the specific heat of said heat transfer means is altered to accomplish useful work.

3. A heat pump comprising a rapidly rotatable generator formed of spin nuclei material, a relatively stationary body of spin nuclei material closely juxtaposed to said generator and forming therewith a closed field circuit, and heat transfer means formed of spin nuclei material and adapted to move through the vicinity of said relatively stationary body whereby the specific heat of said heat transfer means is altered to accomplish useful work.

4. A heat pump according to claim 3, including adjustable means for controlling the rate of heat flow to said heat transfer means or from said heat transfer means.

5. A heat pump according to claim 3, comprising a duct system for exposing a fluid to said heat transfer means for heating or for cooling or for heating and cooling said fluid.

6. A heat pump according to claim 3, comprising a pair of fluid conducting ducts adapted respectively to lead fluid to separated heat transfer areas of said heat transfer means for heating and cooling respective portions of said fluid.

7. A heat pump according to claim 6, including adjustable baffle means for changing the fluid flow through one or both of said fluid conducting ducts.

8. A heat pump according to claim 3, wherein said heat transfer means comprises a ring member formed of spin nuclei material and rotatable between an increased-temperature heat flow zone adjacent said closed field circuit and a reduced-temperature heat flow zone remote from said closed field circuit.

9. A heat pump according to claim 8, wherein said ring member is rotatable about an axis transverse to the axis of rotation of said generator.

10. A heat pump according to claim 8, wherein said ring member is rotatable about an axis parallel to the axis of rotation of said generator.

11. A heat pump according to claim 3, wherein said rotatable generator is axially elongated to provide maximum utilizable spin nuclei material within acceptable limits of centrifugal force.

* * * * *